



HOSHIZAKI

Instruction Manual

Self-Contained Cuber

Model
IM-50BAA-Q



hoshizakiamerica.com

Issued: 12-20-2019

⚠ WARNING

Only qualified service technicians should install and service the appliance. To obtain the name and phone number of your local Hoshizaki Certified Service Representative, visit www.hoshizaki.com. No installation or service should be undertaken until the technician has thoroughly read this Instruction Manual. Likewise, the owner/manager should not proceed to operate the appliance until the installer has instructed them on its proper operation. Failure to install, operate, and maintain the appliance in accordance with this manual will adversely affect safety, performance, component life, and warranty coverage and may result in costly water damage. Proper installation is the responsibility of the installer. Product failure or property damage due to improper installation is not covered under warranty.

Hoshizaki provides this manual primarily to assist qualified service technicians in the installation, maintenance, and service of the appliance.

Should the reader have any questions or concerns which have not been satisfactorily addressed, please call, send an e-mail message, or write to the Hoshizaki Technical Support Department for assistance.

Phone: 1-800-233-1940; (770) 487-2331

Fax: 1-800-843-1056; (770) 487-3360

E-mail: techsupport@hoshizaki.com

HOSHIZAKI AMERICA, INC.

618 Highway 74 South

Peachtree City, GA 30269

Attn: Hoshizaki Technical Support Department

NOTE: To expedite assistance, all correspondence/communication MUST include the following information:

- Model Number _____
- Serial Number _____
- Complete and detailed explanation of the problem.

IMPORTANT

This manual should be read carefully before the appliance is installed and operated. Read the warnings and guidelines contained in this manual carefully as they provide essential information for the continued safe use and maintenance of the appliance. Retain this manual for any further reference that may be necessary.

| CONTENTS | PAGE |
|--------------------------------------------------------------|-------------|
| Important Safety Information----- | 3 |
| I. Specifications ----- | 5 |
| A. Electrical and Refrigerant Data ----- | 5 |
| B. Dimensions/Connections----- | 6 |
| II. Installation and Operating Instructions----- | 7 |
| A. Location ----- | 7 |
| B. Checks Before Installation ----- | 8 |
| C. How to Remove Panels ----- | 8 |
| D. Setup ----- | 10 |
| E. Electrical Connection----- | 11 |
| F. Water Supply and Drain Connections ----- | 12 |
| 1. Icemaker ----- | 13 |
| G. Final Checklist ----- | 14 |
| H. Startup ----- | 15 |
| I. Display ----- | 16 |
| III. Maintenance ----- | 17 |
| A. Maintenance Schedule ----- | 17 |
| B. Cleaning and Sanitizing Instructions ----- | 18 |
| 1. Before Cleaning Procedure----- | 18 |
| 2. Cleaning Procedure ----- | 19 |
| 3. Before Sanitizing Procedure ----- | 20 |
| 4. Sanitizing Procedure - Following Cleaning Procedure ----- | 21 |
| 5. After Sanitizing Procedure ----- | 21 |
| IV. Preparing the Icemaker for Periods of Non-Use----- | 22 |
| V. Disposal ----- | 23 |

Important Safety Information

Throughout this manual, notices appear to bring your attention to situations which could result in death, serious injury, damage to the appliance, or damage to property.

⚠ WARNING Indicates a hazardous situation which could result in death or serious injury.

NOTICE Indicates a situation which could result in damage to the appliance or property.

IMPORTANT Indicates important information about the installation, use, and care of the appliance.

⚠ WARNING

The appliance should be destined only to the use for which it has been expressly conceived. Any other use should be considered improper and therefore dangerous. The manufacturer cannot be held responsible for injury or damage resulting from improper, incorrect, and unreasonable use. Failure to install, operate, and maintain the appliance in accordance with this manual will adversely affect safety, performance, component life, and warranty coverage and may result in costly water damage.

To reduce the risk of death, electric shock, serious injury, or fire, follow basic precautions including the following:

- Only qualified service technicians should install and service the appliance.
- The appliance must be installed in accordance with applicable national, state, and local codes and regulations.
- The appliance requires an independent power supply of proper capacity. See the nameplate for electrical specifications. Failure to use an independent power supply of proper capacity can result in a tripped breaker, blown fuse, damage to existing wiring, or component failure. This could lead to heat generation or fire.
- **THE APPLIANCE MUST BE GROUNDED:** The appliance is equipped with a NEMA 5-15 three-prong grounding plug to reduce the risk of potential shock hazards. It must be plugged into a properly grounded, independent 3-prong wall outlet. If the outlet is a 2-prong outlet, it is your personal responsibility to have a qualified electrician replace it with a properly grounded, independent 3-prong wall outlet. Do not remove the ground prong from the plug and do not use an adapter plug. Failure to properly ground the appliance could result in death or serious injury.
- Do not use an extension cord.
- To reduce the risk of electric shock, do not touch the control switch or plug with damp hands. Make sure the control switch is in the "OFF" position before plugging in or unplugging the appliance.
- Do not use an appliance with a damaged power cord. The power cord should not be altered, jerked, bundled, weighed down, pinched, or tangled. Such actions could result in electric shock or fire. To unplug the appliance, be sure to pull the plug, not the cord, and do not jerk the cord.
- Do not make any alterations to the appliance. Alterations could result in electric shock, injury, fire, or damage to the appliance.

⚠ WARNING, continued

- The appliance is not intended for use by persons (including children) with reduced physical, sensory, or mental capabilities, or lack of experience and knowledge, unless they have been given supervision or instruction concerning use of the appliance by a person responsible for their safety.
- Children should be properly supervised around the appliance.
- Do not climb, stand, or hang on the appliance or appliance door or allow children or animals to do so. Serious injury could occur or the appliance could be damaged.
- Be careful not to pinch fingers when opening and closing the door. Be careful when opening and closing the door when children are in the area.
- Do not use combustible spray or place volatile or flammable substances near the appliance. They might catch fire.
- Keep the area around the appliance clean. Dirt, dust, or insects in the appliance could cause harm to individuals or damage to the appliance.

NOTICE

- Protect the floor when moving the appliance to prevent damage to the floor.
- Follow the water supply, drain connection, and maintenance instructions carefully to reduce the risk of costly water damage.
- In areas where water damage is a concern, install in a contained area with a floor drain.
- Install the appliance in a location that stays above freezing. Normal operating ambient temperature must be within 45°F to 100°F (7°C to 38°C).
- If water collects in the bin and will not drain, turn off the appliance and close the water supply line shut-off valve. Call for service.
- Do not leave the appliance on during extended periods of non-use, extended absences, or in sub-freezing temperatures. To properly prepare the appliance for these occasions, follow the instructions in "IV. Preparing the Appliance for Periods of Non-Use."
- Keep ventilation openings, in the appliance enclosure or in the built-in structure, clear of obstruction.
- Do not place more than 33 lb. (15 kg) on the top panel.
- The ice storage bin is for ice use only. Do not store anything else in the ice storage bin.

I. Specifications

A. Electrical and Refrigerant Data

The rating label and nameplate provide electrical and refrigerant data. The rating label can be seen by removing the front panel. The nameplate is located on the side panel. For certification marks, see the nameplate.

We reserve the right to make changes in specifications and design without prior notice.

| | |
|-----------------------|-----------------------|
| Model Number | IM-50BAA-Q |
| AC Supply Voltage | 115/60/1 |
| Freeze Cycle Amperes | 5.0A |
| Harvest Cycle Amperes | 5.5A (Max.) |
| Design Pressure | HI-218PSIG LO-102PSIG |
| Refrigerant | R134a 7.1 oz. |

B. Dimensions/Connections

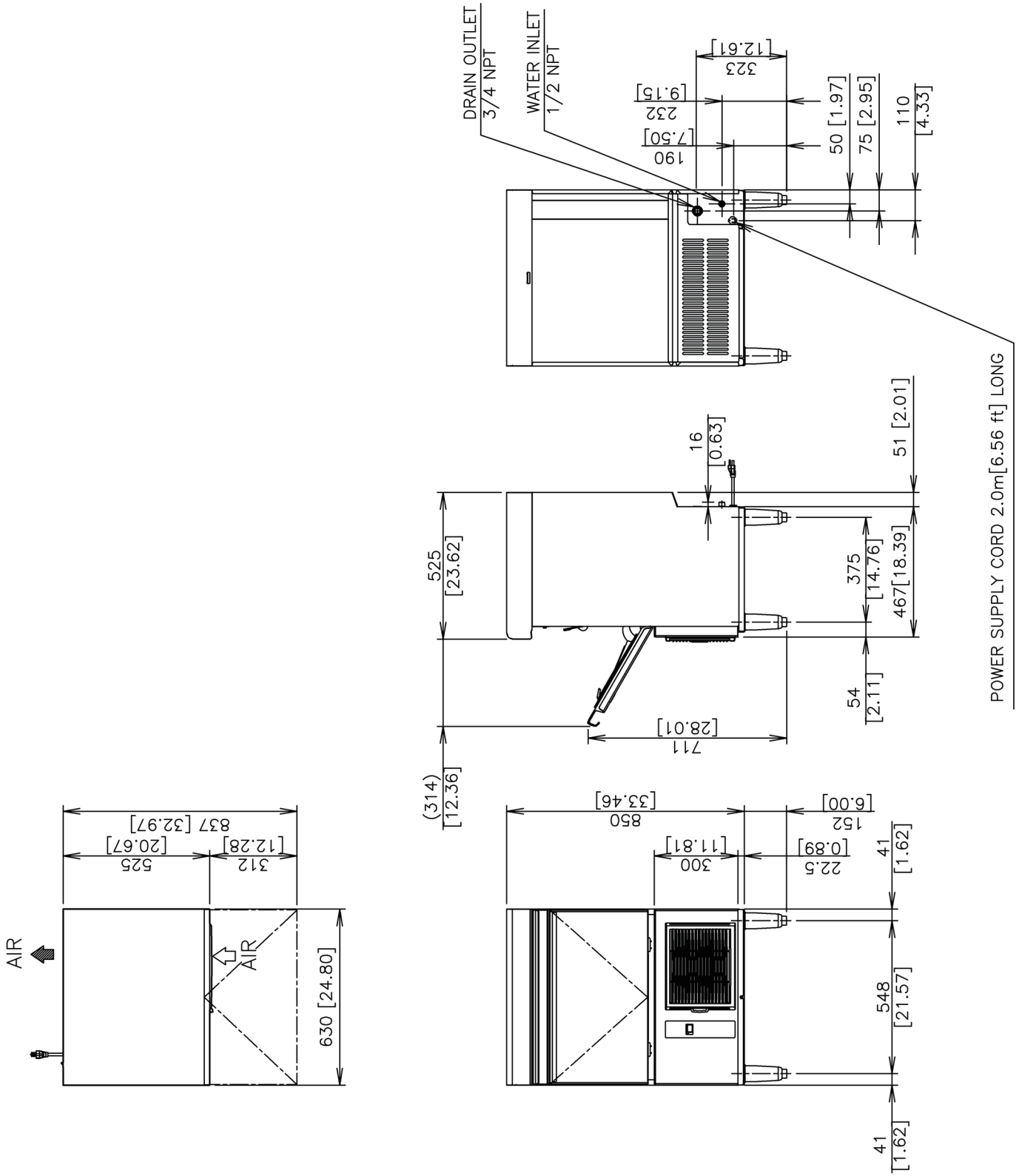

II. Installation and Operating Instructions

WARNING

- The appliance must be installed in accordance with applicable national, state, and local codes and regulations.
- Failure to install, operate, and maintain the appliance in accordance with this manual will adversely affect safety, performance, component life, and warranty coverage and may result in costly water damage.
- **CHOKING HAZARD:** Ensure all components, fasteners, and thumbscrews are securely in place after installation. Make sure that none have fallen into the ice storage bin.

A. Location

NOTICE

- The appliance is not intended for outdoor use. Normal operating ambient temperature must be within 45°F to 100°F (7°C to 38°C); Normal operating water temperature must be within 45°F to 90°F (7°C to 32°C). Operation of the appliance, for extended periods, outside of these normal temperature ranges may affect appliance performance.
- The appliance will not work at sub-freezing temperatures. To prevent damage to the water supply line, drain the appliance if the air temperature is going to go below 32°F (0°C). See "IV. Preparing the Appliance for Periods of Non-Use."

For best operating results:

- The appliance should not be located next to ovens, grills, or other high heat producing equipment.
- In areas where water damage is a concern, install in a contained area with a floor drain.
- Minimum Clearance:

| Top | Left Side and Right Side | Rear |
|------------|----------------------------------------------------------------------------------------------------|-------------|
| 6" (15 cm) | 0" on Left Side and 6" (15 cm) on Right Side or 6" (15 cm) on Left Side and 0" on Right Side | 6" (15 cm) |

- The location must provide a firm and level foundation for the appliance.

B. Checks Before Installation

NOTICE

- Remove all shipping cartons, tape, and packing material. If any are left in the appliance, it will not work properly.
 - Remove the shipping tape holding the door and the bin control actuator.
-
- Visually inspect the exterior of the shipping container and immediately report any damage to the carrier. Upon opening the container, any concealed damage should also be immediately reported to the carrier.
 - Remove the package containing the accessories.
 - Remove the protective plastic film from the panels. If the appliance is exposed to the sun or to heat, remove the film after the appliance cools.
 - Check that refrigerant lines do not rub or touch lines or other surfaces, and that the fan blade turns freely.
 - Check that the compressor is snug on all mounting pads.
 - See the nameplate on the right side panel and check that your voltage supplied corresponds with the voltage specified on the nameplate.

C. How to Remove Panels

See Fig. 1

- Bracket - Top Panel: Remove the screws and pull towards you.
- Top Panel: Lift up.
- Top Insulation: Lift up.
- Top Cover: Lift up.
- Front Panel (Lower): Loosen the screws. Lift up and pull towards you.

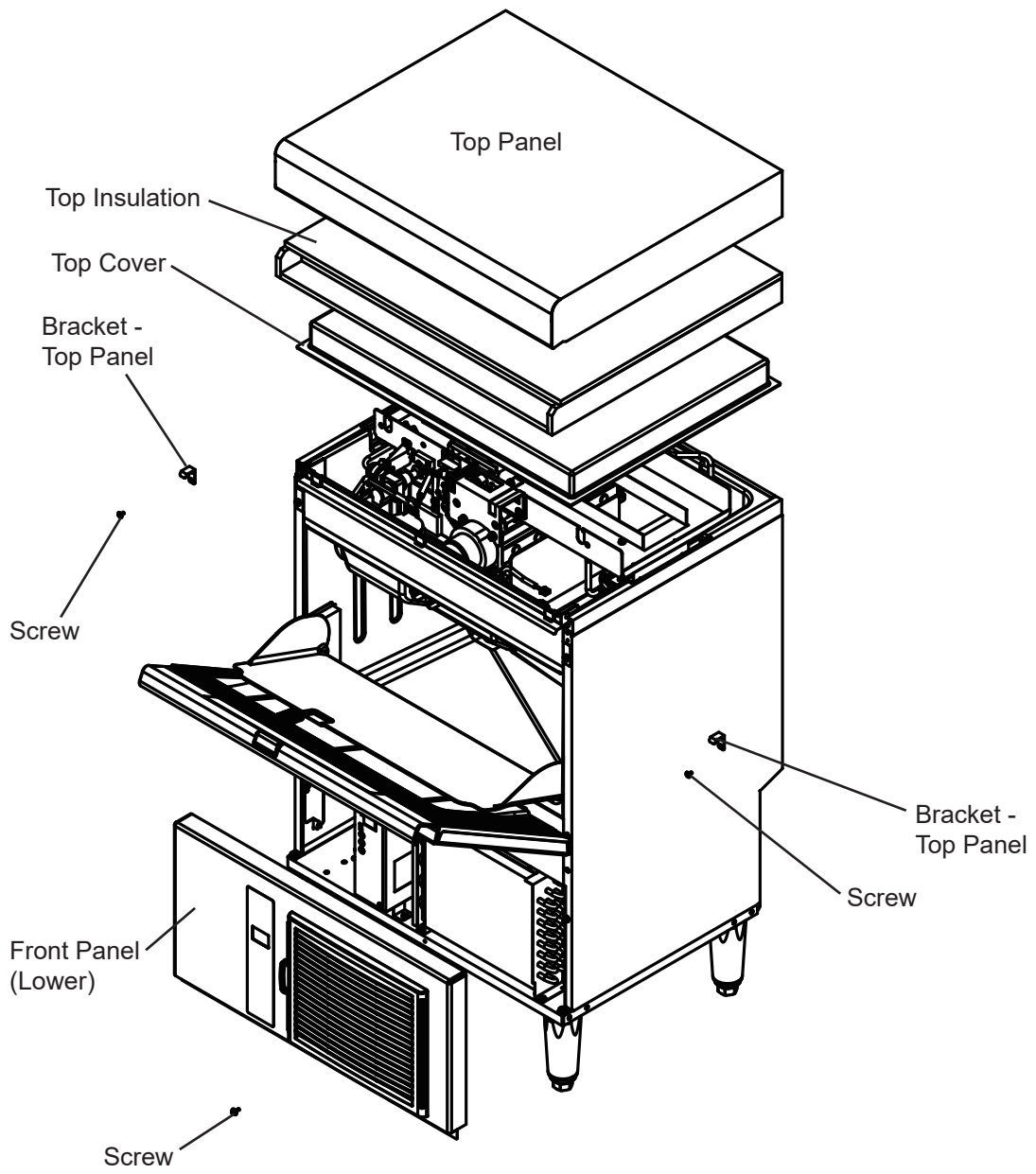

Fig. 1

D. Setup

NOTICE

- Do not place more than 33 lb. (15 kg) on the top panel.
- Do not use the frame to lift the appliance. Lift the appliance from the base.
- Handle the appliance carefully to avoid damaging the exterior.

- 1) Attach the four adjustable legs provided to the bottom of the appliance.
- 2) Position the appliance in the selected permanent location.
- 3) Level the appliance from side-to-side and front-to-rear by adjusting the legs.

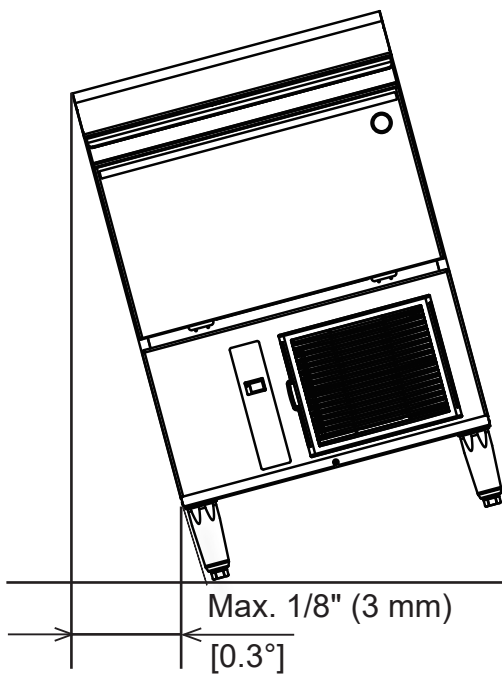

Fig. 2

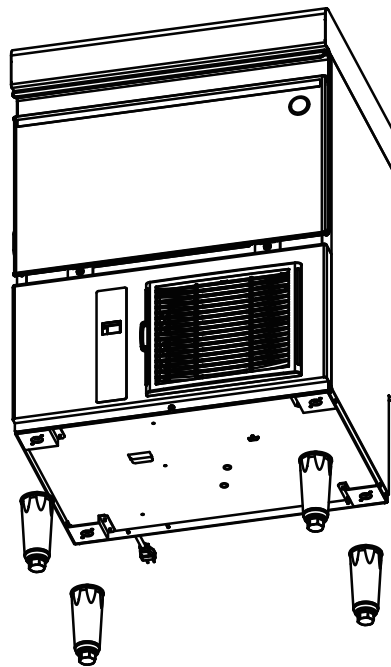

Fig. 3

E. Electrical Connection

WARNING

- Electrical connection must meet national, state, and local electrical code requirements. Failure to meet these code requirements could result in death, electric shock, serious injury, fire, or damage.
 - The appliance requires an independent power supply of proper capacity. See the nameplate for electrical specifications. Failure to use an independent power supply of proper capacity can result in a tripped breaker, blown fuse, damage to existing wiring, or component failure. This could lead to heat generation or fire.
 - **THE APPLIANCE MUST BE GROUNDED:** The appliance is equipped with a NEMA 5-15 three-prong grounding plug to reduce the risk of potential shock hazards. It must be plugged into a properly grounded, independent 3-prong wall outlet. If the outlet is a 2-prong outlet, it is your personal responsibility to have a qualified electrician replace it with a properly grounded, independent 3-prong wall outlet. Do not remove the ground prong from the plug and do not use an adapter plug. Failure to properly ground the appliance could result in death or serious injury.
 - Do not use an extension cord.
 - To reduce the risk of electric shock, do not touch the control switch or plug with damp hands. Make sure the control switch is in the "OFF" position before plugging in or unplugging the appliance.
 - Do not use an appliance with a damaged power cord. The power cord should not be altered, jerked, bundled, weighed down, pinched, or tangled. Such actions could result in electric shock or fire. To unplug the appliance, be sure to pull the plug, not the cord, and do not jerk the cord.
 - The GREEN ground wire in the factory-installed power cord is connected to the appliance. If it becomes necessary to remove or replace the power cord, be sure to connect the power cord's ground wire to this screw upon reattachment.
- Usually an electrical permit and services of a licensed electrician are required.
 - The maximum allowable voltage variation is ± 10 percent of the nameplate rating.

F. Water Supply and Drain Connections - See Fig. 4

WARNING

Water supply and drain connections must be installed in accordance with applicable national, state, and local regulations.

NOTICE

- Normal operating water temperature should be within 45°F to 90°F (7°C to 32°C). Operation of the appliance, for extended periods, outside of this normal temperature range may affect appliance performance.
 - Water supply pressure must be a minimum of 10 PSIG and a maximum of 113 PSIG. If the pressure exceeds 113 PSIG, the use of a pressure reducing valve is required.
 - To prevent damage to the appliance, do not operate the appliance when the water supply is off, or if the pressure is below 10 PSIG. Do not run the appliance until the proper water pressure is reached.
 - External filters, strainers, or softeners may be required depending on water quality. Contact your local Hoshizaki Certified Service Representative or local Hoshizaki distributor for recommendations.
-
- A plumbing permit and services of a licensed plumber may be required in some areas.
 - The icemaker drain line and water-cooled condenser drain line (if applicable) must be run separately.
 - Drain lines must have 1/4" fall per foot (2 cm per 1 m) on horizontal runs to get a good flow. A vented tee connection is also required for proper flow.
 - Drain lines should not be piped directly to the sewer system. An air gap of a minimum of 2 vertical inches (5 cm) should be between the end of the drain pipes from the icemaker / ice storage bin and water-cooled condenser (if applicable) and the floor drain.

1. Icemaker

| Icemaker Water Supply Inlet | Minimum Icemaker Water Supply Line Size | Icemaker / Ice Storage Bin Drain Outlet | Minimum Icemaker Drain Line Size |
|---------------------------------|---------------------------------------------------|-----------------------------------------|-----------------------------------------|
| 1/2" National Pipe Thread (NPT) | 1/4" Nominal ID Copper Water Tubing or Equivalent | 3/4" National Pipe Thread (NPT) | 3/4" Nominal ID Hard Pipe or Equivalent |

- An icemaker water supply line shut-off valve and drain valve must be installed.
- Be sure there is sufficient extra water supply line and drain line for the appliance to be pulled out for service.

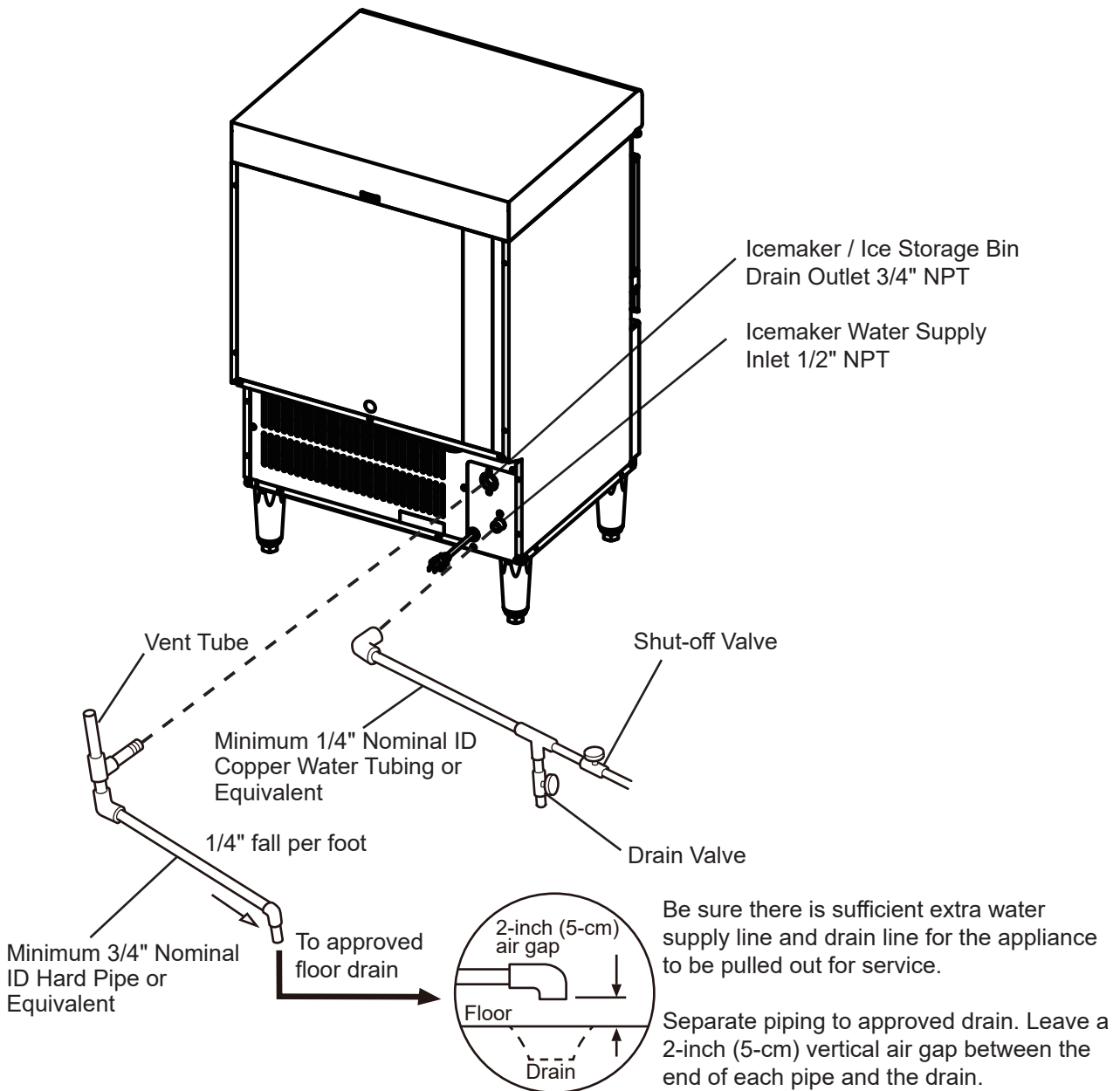

Fig. 4

G. Final Checklist

⚠ WARNING

CHOKING HAZARD: Ensure all components, fasteners, and thumbscrews are securely in place after installation. Make sure that none have fallen into the ice storage bin.

- 1) Is the appliance level?
- 2) Is the appliance in a site where the ambient temperature is within 45°F to 100°F (7°C to 38°C) and the water temperature within 45°F to 90°F (7°C to 32°C) all year around?

- 3) Have the minimum clearance requirements specified below been met?

| Top | Left Side and Right Side | Rear |
|------------|----------------------------------------------------------------------------------------------------|------------|
| 6" (15 cm) | 0" on Left Side and 6" (15 cm) on Right Side or 6" (15 cm) on Left Side and 0" on Right Side | 6" (15 cm) |

- 4) Have all shipping cartons, tape, and packing material been removed from the appliance?
- 5) Have all electrical and water connections been made? Do electrical and water connections meet applicable national, state, and local code and regulation requirements?
- 6) Has the power supply voltage been checked or tested against the nameplate rating? Is the power supply a properly grounded, independent 3-prong wall outlet?
- 7) Are the water supply and drain lines sized as specified? Are the water supply line shut-off valve(s) and drain valve(s) installed? Has the water supply pressure been checked to ensure a minimum of 10 PSIG and a maximum of 113 PSIG?
- 8) Is the compressor snug on all mounting pads? Have the refrigerant lines been checked to make sure they do not rub or touch other lines or surfaces? Has the fan blade (if applicable) been checked to make sure it turns freely?
- 9) Are all components, fasteners, and thumbscrews securely in place?
- 10) Has the end user been given the instruction manual, and instructed on how to operate the appliance and the importance of the recommended periodic maintenance?
- 11) Has the end user been given the contact information of an authorized service agent?
- 12) Has the warranty card been filled out and forwarded to the factory for warranty registration?

H. Startup

WARNING

All parts are factory-adjusted. Improper adjustments may adversely affect safety, performance, component life, and warranty coverage.

NOTICE

- If the appliance is turned off, wait for at least 3 minutes before restarting the appliance to prevent damage to the compressor.
- To prevent damage to the water pump, do not leave the control switch in the "WASH" position for extended periods of time when the water tank is empty.
- At startup, confirm that all internal and external connections are free of leaks.

- 1) Open the door.
- 2) Clean the ice storage bin using a neutral cleaner. Rinse thoroughly after cleaning.
- 3) Close the door.
- 4) Open the water supply line shut-off valve.
- 5) Remove the front panel.
- 6) Make sure the control switch is in the "OFF" position. Plug the appliance into the electrical outlet. **WARNING! To reduce the risk of electric shock, do not touch the control switch or plug with damp hands.**
- 7) Move the control switch to the "ICE" position.
- 8) Replace the front panel in its correct position.

I. Display

1. Normal Operation

Display for normal operation is "on". See the figure on the right.

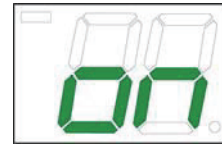

2. Error Code

The unit will show an error code and safely stop if the unit is operating outside of acceptable parameters. See the figure below. If an error code appears, please contact your local Hoshizaki Certified Service Representative for assistance.



- E1: Abnormal freeze cycle
- E2: Abnormal harvest cycle
- EE: Other

III. Maintenance

The appliance must be maintained in accordance with the instruction manual and labels provided. Consult with your local Hoshizaki Certified Service Representative about maintenance service.

|  WARNING | |
|-----------------------------------------------------------------------------------------------------------------------------------------------------------------------------------------------------------------------------------------------------------------------------------------------------------------------------------------------------------------------------------------------------------------------------------------------------------------------------------------------------------------------------------------------------------------------------------------------------------------------------------------------------------------------------------------|--|
| <ul style="list-style-type: none"> • Only qualified service technicians should service the appliance. • To reduce the risk of electric shock, do not touch the control switch or plug with damp hands. Make sure the control switch is in the "OFF" position before plugging in or unplugging the appliance. • Move the control switch to the "OFF" position and unplug the appliance from the electrical outlet before servicing. • CHOKING HAZARD: Ensure all components, fasteners, and thumbscrews are securely in place after any maintenance is done to the appliance. Make sure that none have fallen into the ice storage bin. | |

A. Maintenance Schedule

The maintenance schedule below is a guideline. More frequent maintenance may be required depending on water quality, the appliance's environment, and local sanitation regulations.

| Maintenance Schedule | | |
|-----------------------------|------------------------------------|-----------------------------------------------------------------------------------------------------------------------------------------------------------------------------------------------------|
| Frequency | Area | Task |
| Daily | Scoop | Clean the ice scoop using a neutral cleaner. Rinse thoroughly after cleaning. |
| Bi-Weekly | Air Filters | Inspect. Wash with warm water and neutral cleaner if dirty. |
| Monthly | External Water Filters | Check for proper pressure and change if necessary. |
| | Icemaker Exterior | Wipe down with a clean, soft cloth. Use a damp cloth containing a neutral cleaner to wipe off oil or dirt build up. Clean any chlorine staining (rust colored spots) using a non-abrasive cleanser. |
| Yearly | Icemaker and Ice Storage Bin Liner | Clean and sanitize per the cleaning and sanitizing instructions provided in this manual or on the maintenance label on the icemaker. |
| | Water Supply Inlet | Close the icemaker water supply line shut-off valve and drain the water system. Clean the water supply inlet screen. |
| | Condenser | Inspect. Clean if necessary by using a brush or vacuum cleaner. More frequent cleaning may be required depending on location. |
| | Water Hoses | Inspect the water hoses and clean/replace if necessary. |

B. Cleaning and Sanitizing Instructions

The appliance must be cleaned and sanitized at least once a year. More frequent cleaning and sanitizing may be required in some water conditions.

⚠ WARNING

- To prevent injury to individuals and damage to the appliance, do not use ammonia type cleaners.
- Carefully follow any instructions provided with the bottles of cleaning and sanitizing solution.
- Always wear liquid-proof gloves and goggles to prevent the cleaning and sanitizing solutions from coming into contact with skin or eyes.

NOTICE

To prevent damage to the water pump, do not leave the control switch in the "WASH" position for extended periods of time when the water tank is empty.

1. Before Cleaning Procedure

1) Remove the front panel (lower). Press the "RESET" button on the control box. See Fig. 7. Replace the front panel (lower).

* The water pan opens automatically. After all ice drops from the evaporator, the water pan closes. (It may take about 10 minutes when ambient temperature is low.)

* When the bin control switch is in the "ON" position, the appliance stops with the water pan open. When the "RESET" button on the control box is pressed, the water pan starts to close. After 10 seconds, the water pan starts to open again and the appliance stops when the water pan fully opens.

2) Remove the front panel (lower). Move the control switch on the control box to the "OFF" position and unplug the appliance.

3) Remove all ice from the ice storage bin.

4) Remove the front frame. Pull off the drain pan towards you. See Fig. 5.

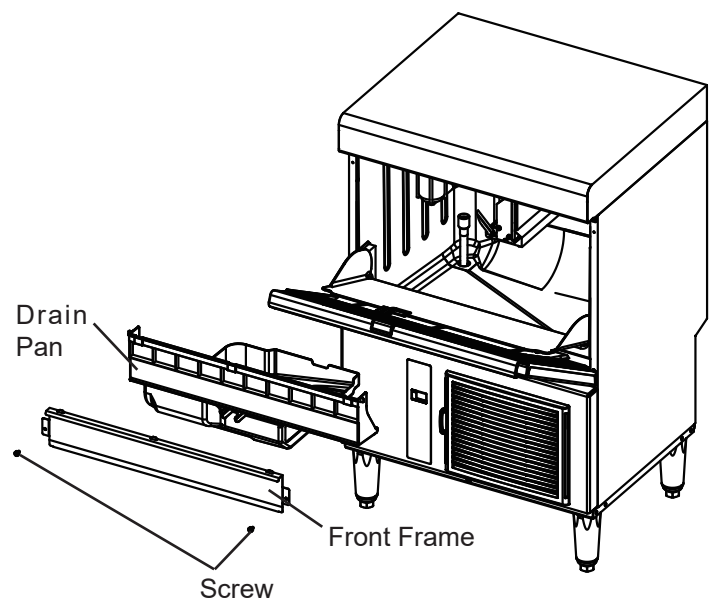

Fig. 5

- 5) Remove the ice guide from the unit frame. See Figs. 6 and 6-1.

[How to remove ice guide] See Fig. 6-2.

- (1) Remove the ice plate.
- (2) Remove the shaft.
- (3) Pull off the ice guide towards you.

- 6) Replace the front frame and the drain pan.

- 7) Close the icemaker water supply line shut-off valve. See Fig. 4.

- 8) Plug in the appliance. Remove the front panel (lower). Move the control switch on the control box to the "ICE" position.

* After 30 seconds, the appliance starts up to open the water pan automatically, drain the icemaking water in the water tank and close the water pan.

- 9) When icemaking water remains in the water tank, press the "RESET" button on the control box again.

* The water pan opens automatically and then closes immediately. (It takes about 60 seconds for the water pan to open and close to the horizontal position.)

- 10) Move the control switch on the control box to the "OFF" position. Replace the front panel (lower). Unplug the appliance.

- 11) Open the icemaker water supply line shut-off valve. See Fig. 4.

2. Cleaning Procedure

- 1) Dilute approximately 2.9 fl. oz (86 ml) of recommended cleaner Hoshizaki "Scale Away" with 0.32 gallon (1.2 lit.) of water.

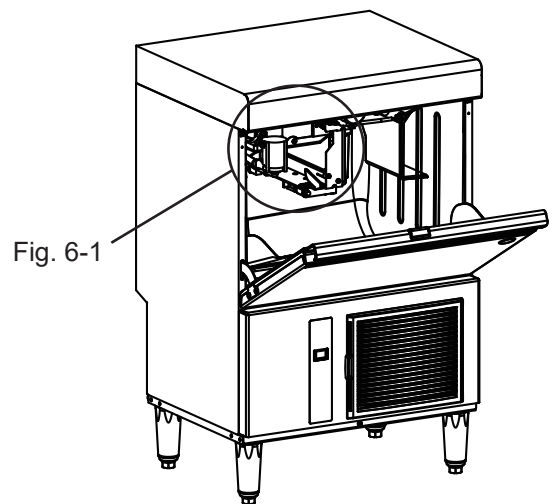

Fig. 6

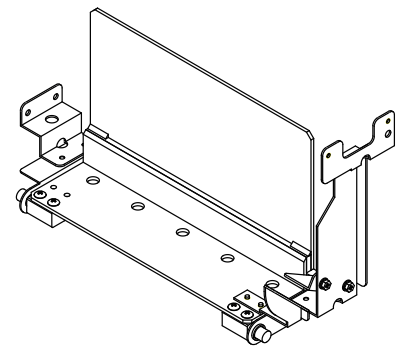

Fig. 6-1

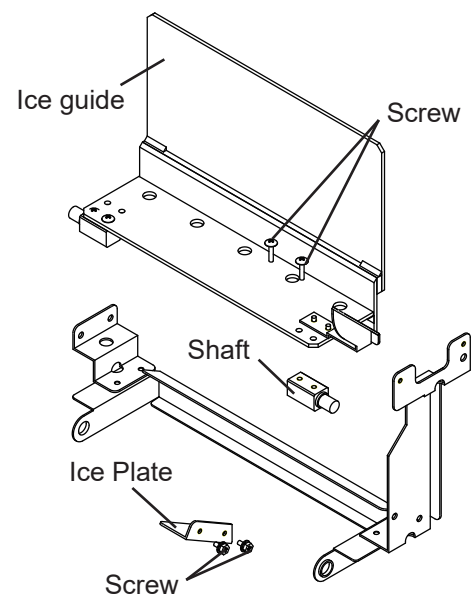

Fig. 6-2

2) Check the water pan is fully closed and then slowly pour the cleaning solution over the top of the water tank. Do not splash or spill the solution onto other parts. Replace the front panel (lower).

3) Plug in the appliance. Remove the front panel (lower). Move the control switch on the control box to the “WASH” position. Replace the front panel (lower).

* After 30 seconds, the appliance starts up to circulate the cleaning solution with the pump motor.

* Allow the appliance to circulate the cleaning solution for 30 minutes.

4) Remove the front panel (lower). Press the “RESET” button on the control box. Replace the front panel (lower).

* The water pan opens automatically and stops for 30 seconds, while the appliance drains the cleaning solution in the water tank. After 30 seconds, when the water pan starts to close, tap water is supplied from the water valve and stored in the water tank. When the water pan closes fully, the pump motor circulates tap water to rinse the water circuit.

* Allow the appliance to circulate the rinse water for 3 minutes.

5) Repeat step 4 two more times to rinse thoroughly.

6) Remove the front panel (lower). Press the “RESET” button on the control box. The water pan opens automatically and stops for 30 seconds, while the appliance drains the rinse water in the water tank.

7) While the water pan stays open, move the control switch on the control box to the “OFF” position. Replace the front panel (lower).

Note: If not sanitizing the icemaker, go to “III. B. 5. After Sanitizing Procedure”.

3. Before Sanitizing Procedure

1) Close the icemaker water supply line shut-off valve. See Fig. 4. Remove the front panel (lower). Move the control switch on the control box to the “ICE” position.

* After 30 seconds, the appliance starts up to close the water pan automatically. (It takes about 30 seconds for the water pan to close.)

2) Move the control switch on the control box to the “OFF” position. Replace the front panel (lower). Unplug the appliance.

3) Open the icemaker water supply line shut-off valve. See Fig. 4.

4. Sanitizing Procedure - Following Cleaning Procedure

- 1) Dilute 8.25% sodium hypochlorite solution (chlorine bleach) with water (add approximately 0.1 fl. oz. (2.9 ml) to 0.32 gal. (1.2 lit.) of water).
- 2) Check the water pan is fully closed and slowly pour the sanitizing solution over the top of the water tank. Do not splash or spill the solution onto other parts.
- 3) Plug in the appliance. Remove the front panel (lower). Move the control switch on the control box to the "WASH" position. Replace the front panel (lower).

* After 30 seconds, the appliance starts up to circulate the sanitizing solution with the pump motor.

* Allow the appliance to circulate the sanitizing solution for 15 minutes.

- 4) Remove the front panel (lower). Press the "RESET" button on the control box. Replace the front panel (lower).

* The water pan opens automatically and stops for 30 seconds, while the appliance drains the sanitizing solution in the water tank. After 30 seconds, when the water pan starts to close, tap water is supplied from the water valve and stored in the water tank. When the water pan closes fully, the pump motor circulates tap water to rinse the water circuit.

* Allow the appliance to circulate the rinse water for 3 minutes.

- 5) Repeat step 4 two more times to rinse thoroughly.

- 6) Remove the front panel (lower). Press the "RESET" button on the control box.

* The water pan opens automatically and stops for 30 seconds, while the appliance drains the rinse water in the water tank.

- 7) While the water pan stays open, move the control switch on the control box to the "OFF" position. Replace the front panel (lower).

- 8) Repeat steps 1 through 7 one more time.

5. After Sanitizing Procedure

- 1) After Remove the front panel (lower). Move the control switch on the control box to the "ICE" position. Replace the front panel (lower).

* After 30 seconds, the appliance starts up to close the water pan automatically. Remove the front panel (lower). Move the control switch on the control box to the "OFF" position. Replace the front panel (lower).

- 2) Remove the front frame. Pull off the drain pan towards you. See Fig. 5.
- 3) Clean the ice storage bin liner, drain pan, and ice guide using a neutral cleaner. Rinse thoroughly after cleaning.
- 4) Replace the ice guide. See Figs. 6, 6-1 and 6-2.
- 5) Replace the front frame and drain pan. See Fig. 5.
- 6) Plug in the appliance.
- 7) Remove the front panel (lower). Move the control switch on the control box to the "ICE" position. Replace the front panel (lower).

* After 30 seconds, the appliance starts up to start the automatic icemaking process.

IV. Preparing the Appliance for Periods of Non-Use

| <i>NOTICE</i> |
|-------------------------------------------------------------------------------------------------------------------------------------------------------------------------------------------------------------------------------------------------------------------------------------------------------------------------------------------------------------------------------------|
| <ul style="list-style-type: none">• During extended periods of non-use, extended absences, or in sub-freezing temperatures, follow the instructions below to reduce the risk of costly water damage.• To prevent damage to the water pump, do not leave the control switch in the "WASH" position for extended periods of time when the water tank is empty. |

During extended periods of non-use, extended absences, or in sub-freezing temperatures, follow the instructions below. When the appliance is not used for two or three days under normal conditions, it is sufficient to move the control switch to the "OFF" position.

1. Remove the water from the icemaker water supply line:

- 1) Remove the front panel (lower). Move the control switch to the "OFF" position. Replace the front panel (lower).
- 2) Close the icemaker water supply line shut-off valve and then open the icemaker water supply line drain valve. See Fig. 4.
- 3) Allow the icemaker water supply line to drain by gravity.

4) Attach compressed air or carbon dioxide supply to the icemaker water supply line drain valve.

5) Remove the front panel (lower). Move the control switch on the control box to the "ICE" position. Replace the front panel (lower).

* After 30 seconds, the appliance starts up.

6) Blow the icemaker water supply line out using compressed air or carbon dioxide.

7) Remove the front panel (lower). Move the control switch on the control box to the "OFF" position. Replace the front panel (lower). Close the icemaker water supply line shut-off valve. See Fig. 4.

2. Drain the water tank:

1) Remove the front panel (lower). Move the control switch on the control box to the "ICE" position.

* After 30 seconds, the appliance starts up to open the water pan automatically and drain the icemaking water in the water tank.

Note: This procedure is necessary to protect the appliance from freezing up at sub-freezing temperatures.

2) Remove the front panel (lower) with the water pan open. Move the control switch on the control box to the "OFF" position. Replace the front panel (lower).

3) Unplug the appliance.

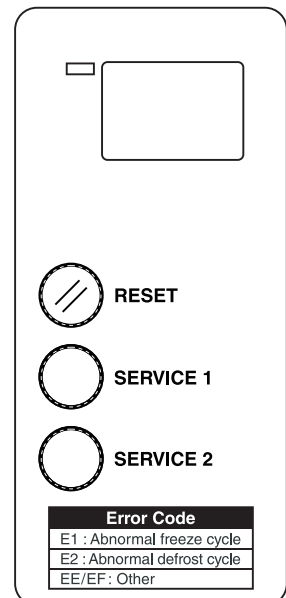

Fig. 7

V. Disposal

The appliance contains refrigerant and must be disposed of in accordance with applicable national, state, and local codes and regulations. Refrigerant must be recovered by properly certified service personnel.

IMPORTANT



The insulation foaming agent used for the unit body contains the flammable gas cyclopentane. With this in mind, dispose of the product properly.

HOSHIZAKI AMERICA, INC.

618 Hwy. 74 South, Peachtree City, GA 30269 USA (P) 770.487.2331 (F) 770.487.3360 hoshizakiamerica.com | L1M041101